

# Wireless LAN Application Notes (001)

## Wireless LAN Setting

Version 2.1



Sollae Systems Co., Ltd.

---

# 1. Wireless LAN Types and Setting

Wireless LAN supports Infrastructure mode implemented using AP (Access Point) and Ad-hoc mode implemented without AP.

## 1.1. Infrastructure

In infrastructure mode, network is configured through AP.

Interworking with wired as well as wireless LAN is allowed when network is configured through AP.

### 1.1.1. Network Configuration

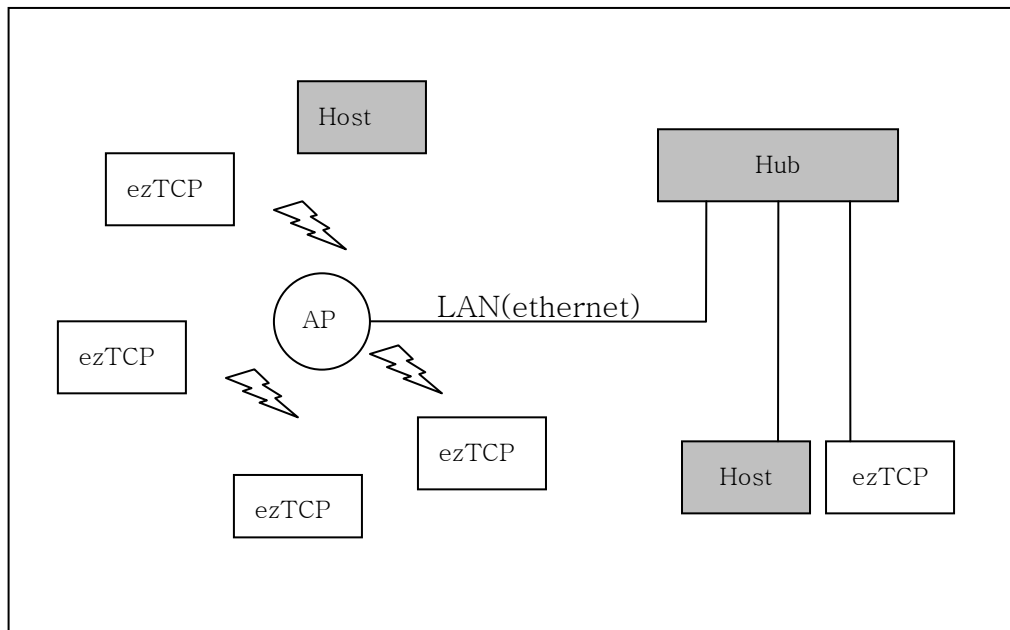

### 1.1.2. Features

In infrastructure mode based on AP, interworking with wired LAN is allowed and communication range is longer than that in ad-hoc mode.

### 1.1.3. ezTCP setting

- WLAN Mode

It should be configured as Infrastructure.

- Target SSID

SSID identifies the network. You should set AP SSID to ezTCP SSID.

- Channel

Communication channel of wireless LAN is divided by frequency. If you set channel to 0, communication goes through the AP channel when AP is connected.

- WEP

You should set WEP to apply security to your wireless LAN. When AP SSID is set, you should also set the WEP key and index specified for AP in ezTCP.

#### 1.1.4. Example of Infrastructure Configuration

The example below shows infrastructure configuration using the ezSerialConfig program. In the example, SSID is set to test-ssid, CHANNEL is set to 0, and WEP is not used. (Items pertaining to wireless LAN are marked with red.)

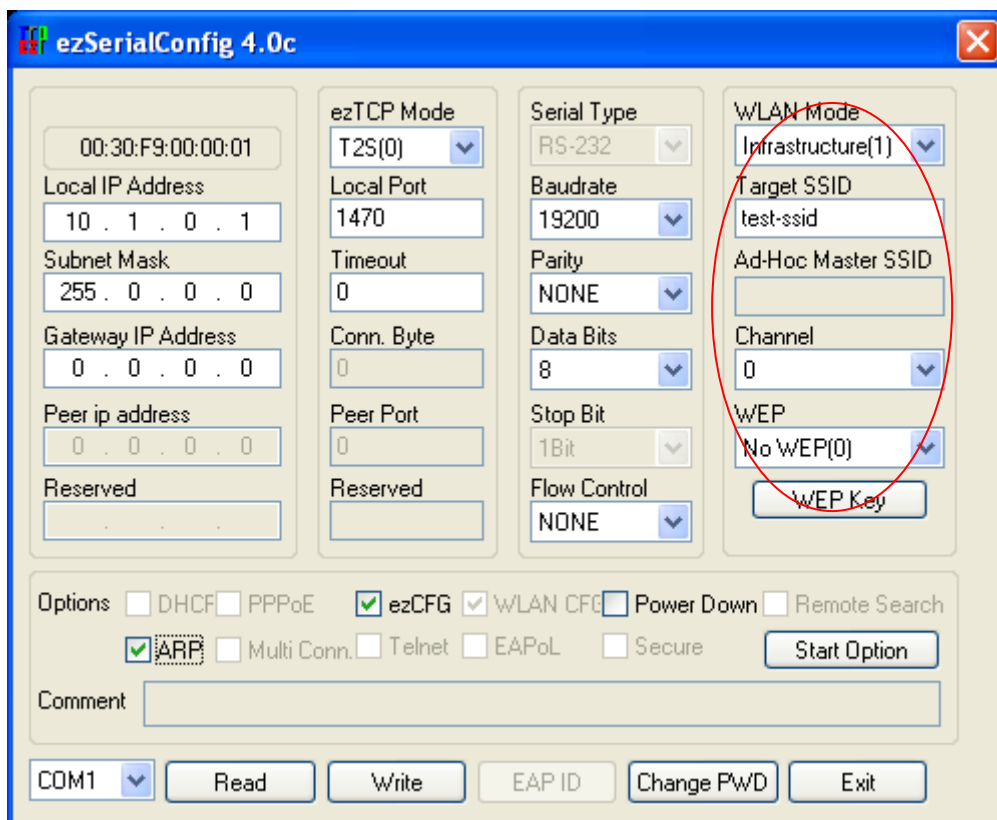

## 1.2. Ad-hoc

In Ad-hoc mode network is configured with wireless LAN equipment without AP.

### 1.2.1. Network Configuration

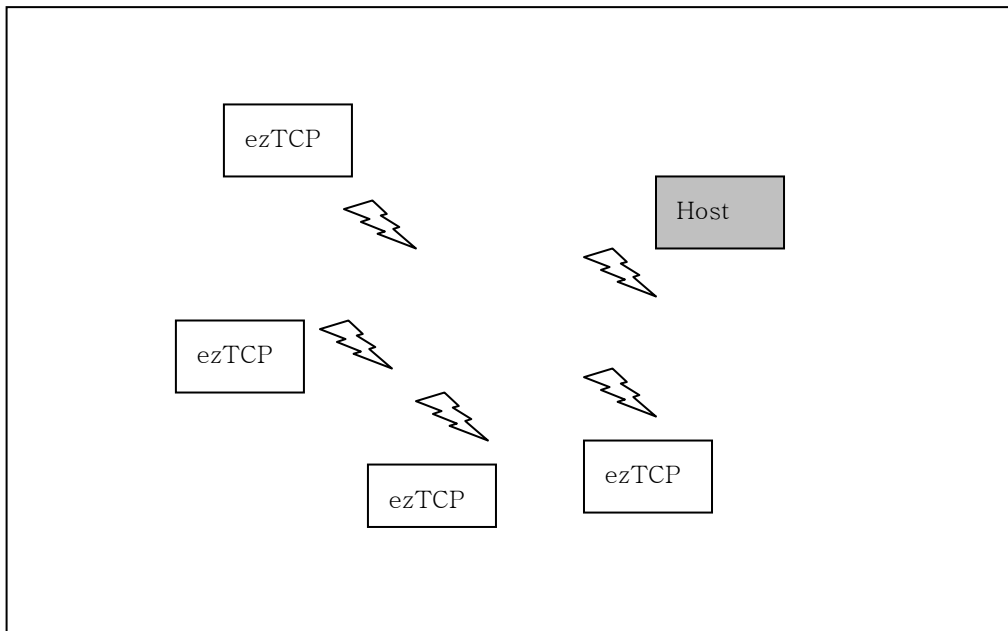

### 1.2.2. Features

Ad-hoc mode has an advantage of saving AP cost because AP is not needed at all. On the other hand, interworking with wired LAN is not allowed and communication distance is comparatively short.

### 1.2.3. ezTCP setting

- WLAN Mode

It should be configured as AD-HOC.

- SSID

SSID identifies the network. You should set Target SSID and Ad-hoc Master SSID with same value to identify the network.

- Channel

Set Channel to 0 for automatic connection.

- WEP

Set WEP to use the security function in the wireless LAN. Set the devices configured in the same network to the same WEP key.

#### 1.2.4. Example of Ad-hoc Configuration

The example below shows Ad-hoc configuration using the ezSerialConfig program. In the example, Target SSID and Ad-Hoc Master SSID are set to same SSID. CHANNEL is set to 0, and WEP is not used. (Items pertaining to wireless LAN are marked with red.)

The screenshot shows the ezSerialConfig 4.0c application window. The interface is divided into several sections:

- MAC Address:** 00:30:F9:00:00:01
- Local IP Address:** 10 . 1 . 0 . 1
- Subnet Mask:** 255 . 0 . 0 . 0
- Gateway IP Address:** 0 . 0 . 0 . 0
- Peer ip address:** 0 . 0 . 0 . 0
- Reserved:** (empty)
- ezTCP Mode:** T2S(0)
- Local Port:** 1470
- Timeout:** 0
- Conn. Byte:** 0
- Peer Port:** 0
- Reserved:** (empty)
- Serial Type:** RS-232
- Baudrate:** 19200
- Parity:** NONE
- Data Bits:** 8
- Stop Bit:** 1Bit
- Flow Control:** NONE
- WLAN Mode:** AD-HOC(0) (circled in red)
- Target SSID:** adhoc-ssid
- Ad-Hoc Master SSID:** adhoc-ssid
- Channel:** 0 (circled in red)
- WEP:** No WEP(0) (circled in red)
- WEP Key:** (empty text box)

**Options:**

- DHCP
- PPPoE
- ezCFG
- WLAN CFG
- Power Down
- Remote Search
- ARP
- Multi Conn.
- Telnet
- EAPoL
- Secure

**Buttons:** Start Option, Comment (text box), COM1 (dropdown), Read, Write, EAP ID, Change PwD, Exit.

---

## 2. Revision History

Date	Version	Comments
Oct.24.2005	1.1	The first release
Dec.06.2005	2.0	Added Revision History Changed all fonts into Times New Roman
Oct.10.2008	2.1	Changed product image