

CSE-M53N / CSE-M53G

Ethernet termination resistors are embedded

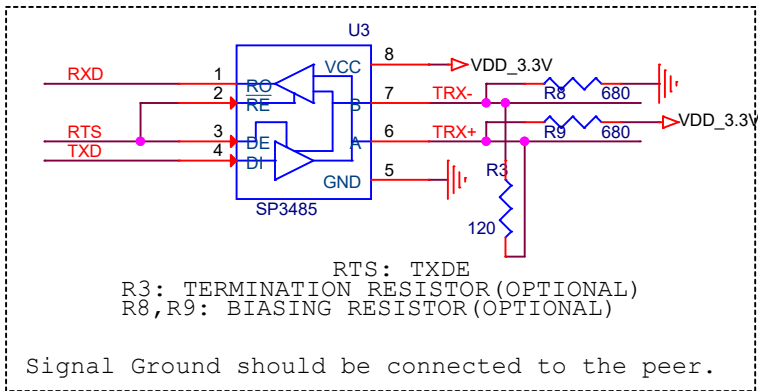
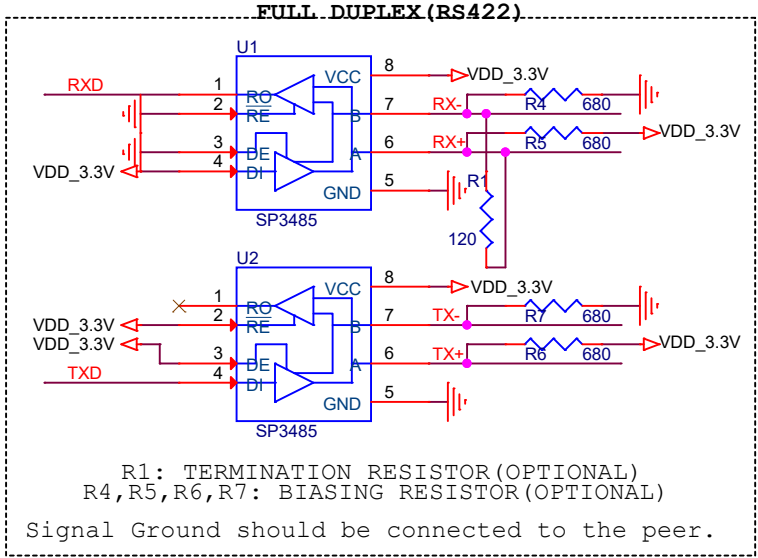
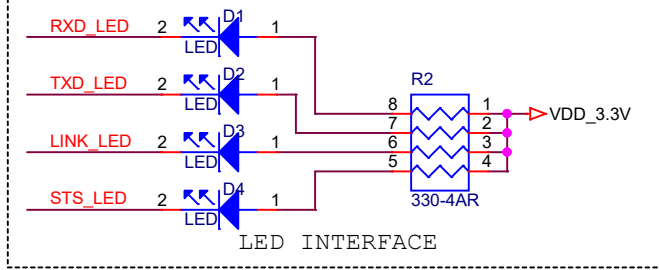
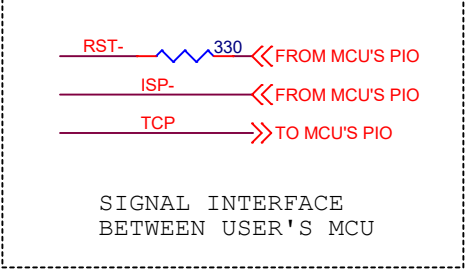

- History
- V1.1 (2010.04.06) - CON1 name change (RD1 -> RDA)
  - V1.2 (2015.01.22) - Added biasing resistor [RS422/485]
  - V1.3 (2018.02.27) - Added a Ferrited Bead for CSE-M53N's Power  
Added a series Resistor into RST-  
Added Comments about singal ground connection for RS422 and RS485
  - V1.4 (2021.12.08) - Added CSE-M53G  
Added Link-PP's RJ45

Title		
CSE-M53N/CSE-M53G Ethernet/RS422/RS485		
Size	Document Number	Rev
A4	MAIN	V1.4
Date:	Wednesday, December 08, 2021	Sheet 1 of 1